



**Dual-Conversion  
1 kHz or 125 kHz  
Step Size**

# SYNTHESIZED COMMUNICATION CONVERTERS

**9600  
SERIES**



**9400  
SERIES**

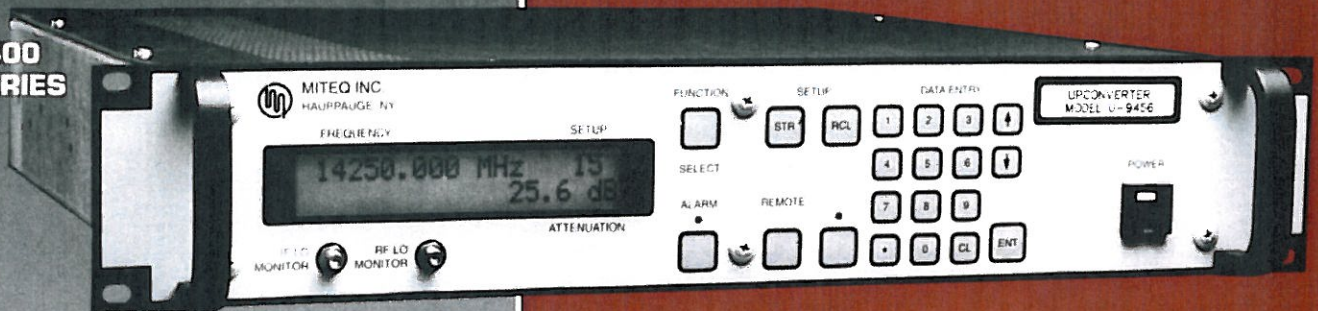

MITEQ offers high-performance synthesized frequency converters in panel heights of 2 RU (9400 Series) and 1 RU (9600 Series). The 9400 series converters are available in frequency step sizes of 1 kHz or 125 kHz. The 9600 series converters are available in 125 kHz frequency step size. These frequency converters operate in the standard communication bands. An internal synthesizer provides frequency tuning. Level control is available via the front panel or the remote control interface.

## OPTIONS

- Output amplifier for increased dynamic range (upconverters)
- Higher stability reference
- RF signal monitor
- Remote RS422, RS232, IEEE-488, BCD contact closure or contact closure interface
- 140 MHz IF frequency
- Higher gain (downconverters)
- 50 ohm IF impedance

## FEATURES

- Local or remote control (RS485 standard)
- Low intermodulation distortion
- Low phase noise
- 32 programmable frequency and attenuation settings
- Nonvolatile memory
- 30 dB level control
- IF signal monitor output, -20 dBc

## UPCONVERTERS

### 2 RU (3.5 INCHES) UPCONVERTERS - 9400 SERIES

Output Frequency (GHz)	125 kHz Step Size Model Number	1 kHz Step Size Model Number	Phase Noise Characteristics
0.95 – 1.45	U-9448	U-9448-1K	Curve 3
0.95 – 1.75	U-9448-1	U-9448-1-1K	Curve 3
0.95 – 2.05	U-9448-3	U-9448-3-1K	Curve 3
1.5 – 1.8	U-9448-2	U-9448-2-1K	Curve 1
3.4 – 4.2	U-9451-1	U-9451-1-1K	Curve 2
3.62 – 4.205	U-9451	U-9451-1K	Curve 1
5.725 – 6.725	U-9453-6	U-9453-6-1K	Curve 2
5.845 – 6.430	U-9453	U-9453-1K	Curve 1
5.85 – 6.485	U-9453-3	U-9453-3-1K	Curve 1
5.85 – 6.665	U-9453-1	U-9453-1-1K	Curve 2
5.85 – 6.725	U-9453-5	U-9453-5-1K	Curve 2
5.95 – 6.725	U-9453-4	U-9453-4-1K	Curve 2
6.7 – 7.1	U-9453-2	U-9453-2-1K	Curve 2
7.9 – 8.4	U-9454	U-9454-1K	Curve 2
10.95 – 12.75	U-9455-3	U-9455-3-1K	Curve 4
11.7 – 12.2	U-9455	U-9455-1K	Curve 3
12.2 – 12.75	U-9455-1	U-9455-1-1K	Curve 3
12.75 – 13.25	U-9455-2	U-9455-2-1K	Curve 3
12.75 – 13.25/14.0 – 14.5	U-9456-1	U-9456-1-1K	Curve 4
12.75 – 13.25/13.75 – 14.5	U-9456-5	U-9456-5-1K	Curve 4
13.75 – 14.5	U-9456-3	U-9456-3-1K	Curve 3
13.75 – 14.8	U-9456-6	U-9456-6-1K	Curve 3
14.0 – 14.5	U-9456	U-9456-1K	Curve 3
14.0 – 14.75	U-9456-2	U-9456-2-1K	Curve 3
14.5 – 14.8	U-9456-4	U-9456-4-1K	Curve 3
17.3 – 17.8	U-9457	U-9457-1K	Curve 4
17.3 – 18.1	U-9457-1	U-9457-1-1K	Curve 4
17.3 – 18.4	U-9457-2	U-9457-2-1K	Curve 4

### 1 RU (1.75 INCHES) UPCONVERTERS - 9600 SERIES

Output Frequency (GHz)	125 kHz Step Size Model Number	Phase Noise Characteristics
5.845 – 6.430	U-9653	Curve 1
5.85 – 6.475	U-9653-3	Curve 1
6.7 – 7.1	U-9653-2	Curve 1
7.9 – 8.4	U-9654	Curve 2
12.75 – 13.25	U-9655-2	Curve 3
13.75 – 14.5	U-9656-3	Curve 3
14.0 – 14.5	U-9656	Curve 3
17.3 – 17.8	U-9657	Curve 4
17.3 – 18.1	U-9657-1	Curve 4
17.3 – 18.4	U-9657-2	Curve 4

## DOWNCONVERTERS

### 2 RU (3.5 INCHES) DOWNCONVERTERS - 9400 SERIES

Input Frequency (GHz)	125 kHz Step Size Model Number	1 kHz Step Size Model Number	Phase Noise Characteristics
0.95 – 1.45	D-9400-1	D-9400-1-1K	Curve 3
0.95 – 1.75	D-9400-3	D-9400-3-1K	Curve 3
0.95 – 2.05	D-9400-5	D-9400-5-1K	Curve 3
1.5 – 1.8	D-9400-2	D-9400-2-1K	Curve 1
1.7 – 2.4	D-9400-4	D-9400-4-1K	Curve 3
2.2 – 2.3	D-9400	D-9400-1K	Curve 1
3.0 – 4.2	D-9401-2	D-9401-2-1K	Curve 2
3.4 – 4.2	D-9401-1	D-9401-1-1K	Curve 2
3.62 – 4.205	D-9402	D-9402-1K	Curve 1
4.5 – 4.8	D-9402-2	D-9402-2-1K	Curve 1
5.845 – 6.430	D-9404	D-9404-1K	Curve 1
6.4 – 7.2	D-9405-1	D-9405-1-1K	Curve 2
7.25 – 7.75	D-9405	D-9405-1K	Curve 2
7.9 – 8.4	D-9406	D-9406-1K	Curve 2
8.0 – 8.5	D-9407	D-9407-1K	Curve 2
10.7 – 11.7	D-9408-2	D-9408-2-1K	Curve 2
10.7 – 12.0	D-9408-5	D-9408-5-1K	Curve 3
10.7 – 12.75	D-9408-6*	D-9408-6-1K*	Curve 3
10.95 – 11.7	D-9408	D-9408-1K	Curve 3
10.95 – 12.2	D-9408-1	D-9408-1-1K	Curve 4
10.95 – 12.75	D-9408-3*	D-9408-3-1K*	Curve 4
11.45 – 12.75	D-9409-3	D-9409-3-1K	Curve 4
11.46 – 11.96	D-9409-2	D-9409-2-1K	Curve 3
11.7 – 12.2	D-9409	D-9409-1K	Curve 3
11.7 – 12.75	D-9409-1	D-9409-1-1K	Curve 3
12.2 – 12.75	D-9410	D-9410-1K	Curve 3
13.75 – 14.5	D-9411-1	D-9411-1-1K	Curve 3
14.0 – 14.5	D-9411	D-9411-1K	Curve 3
17.3 – 17.8	D-9412	D-9412-1K	Curve 4
17.3 – 18.1	D-9412-1	D-9412-1-1K	Curve 4
17.3 – 18.4	D-9412-2	D-9412-2-1K	Curve 4

### 1 RU (1.75 INCHES) DOWNCONVERTERS - 9600 SERIES

Input Frequency (GHz)	125 kHz Step Size Model Number	Phase Noise Characteristics
0.95 – 1.45	D-9600-1	Curve 3
0.95 – 1.75	D-9600-3	Curve 3
1.5 – 1.8	D-9600-2	Curve 1
2.2 – 2.3	D-9600	Curve 1
3.4 – 4.2	D-9601-1	Curve 2
3.62 – 4.205	D-9602	Curve 1
4.5 – 4.8	D-9602-2	Curve 1
6.4 – 7.2	D-9605-1	Curve 2
7.25 – 7.75	D-9605	Curve 2
10.95 – 11.7	D-9608	Curve 3
10.95 – 12.75	D-9608-3*	Curve 4
11.7 – 12.2	D-9609	Curve 3
12.2 – 12.75	D-9610	Curve 3

\* References noise figure under "Downconverter Specifications" section

# SPECIFICATIONS

## UPCONVERTER

## DOWNCONVERTER

Type	Dual conversion	Dual conversion
Tunability	Second local oscillator only	First local oscillator only
Frequency sense	No inversion	No inversion
Input characteristics		
Frequency	70 ±20 MHz (140 ±40 MHz optional)	Refer to model numbers and tables
Impedance	75 ohms (50 ohms optional)	50 ohms
Return loss	26 dB minimum	20 dB minimum
Signal monitor	-20 dBc nominal	Option 2A
LO leakage	N/A	-80 dBm maximum
Output characteristics		
Frequency	Refer to model numbers and tables	70 ±20 MHz (140 ±40 MHz optional)
Impedance	50 ohms	75 ohms (50 ohms optional)
Return loss	20 dB minimum	26 dB minimum
Power output (1 dB compression)	-5 dBm nominal (up to +20 dBm with optional output amplifiers, refer to options)	+15 dBm typical, +10 dBm minimum
Signal monitor	Option 2A	-20 dBc nominal
Transfer characteristics		
Noise figure	20 dB typical, 25 dB maximum	10 dB typical, 12 dB maximum, *12 dB typical, 15 dB maximum
Gain	11 dB nominal (at minimum attenuation)	30 dB nominal (higher gain optional)
Image rejection	80 dB minimum	80 dB minimum
Level stability	±0.25 dB/day maximum at constant temp.	±0.25 dB/day maximum at constant temp.
Amplitude response	±0.25 dB/±20 MHz, ±0.20 dB/±18 MHz	±0.25 dB/±20 MHz, ±0.20 dB/±18 MHz
Group delay (±18 MHz)	0.03 ns/MHz maximum linear, 0.01 ns/MHz <sup>2</sup> maximum parabolic, 1 ns peak-to-peak maximum ripple	0.03 ns/MHz maximum linear, 0.01 ns/MHz <sup>2</sup> maximum parabolic, 1 ns peak-to-peak maximum ripple
Intermodulation distortion (third order)	With two -20 dBm output signals, 50 dBc minimum	With two -10 dBm output signals, 60 dBc minimum
AM/PM conversion	0.1°/dB maximum to -15 dBm output	0.1°/dB maximum to +5 dBm output
Gain slope	0.02 dB/MHz maximum	0.02 dB/MHz maximum
Spurious outputs		
For converters with RF frequencies below 8.5 GHz		
Signal related	65 dBc minimum	65 dBc minimum
Signal independent	-90 dBm maximum -80 dBm maximum (Option 11A) -70 dBm maximum (Option 11B)	-90 dBm maximum -75 dBm maximum (Option 16A) -65 dBm maximum (Option 16C)
For converters with RF frequencies above 8.5 GHz		
Signal related	60 dBc minimum	60 dBc minimum
Signal independent	-90 dBm maximum -80 dBm maximum (Option 11A) -75 dBm maximum (Option 11B)	-90 dBm maximum -75 dBm maximum (Option 16A) -65 dBm maximum (Option 16C)
Gain adjustment	30 dB, local and remote control	30 dB, local and remote control
Gain adjustment step size	0.2 dB	0.2 dB
Frequency stability	±2 × 10 <sup>-8</sup> , 0 to 50°C (higher stability options available), ±5 × 10 <sup>-9</sup> /day typical (fixed temp. after 24 hour on time)	±2 × 10 <sup>-8</sup> , 0 to 50°C (higher stability options available), ±5 × 10 <sup>-9</sup> /day typical (fixed temp. after 24 hour on time)
Upconverter mute	60 dB	N/A
Phase noise	See table for curve and graph designations	See table for curve and graph designations

## OPTIONS

- 2. A.** RF signal monitor.  
Rear panel RF connector (SMA) with -20 dBc nominal level.
- 4. A.** 140 MHz IF frequency.  
Bandwidth: 80 MHz minimum  
Flatness: 0.75 dB/76 MHz  
Group delay ( $\pm 36$  MHz)  
Linear: 0.025 ns/MHz  
Parabolic: 0.0035 ns/MHz<sup>2</sup>  
Ripple: 1 ns peak-to-peak  
IF return loss (140  $\pm$ 40 MHz): 20 dB minimum  
Gain slope: 0.04 dB/MHz maximum (10 MHz minimum)
- B.** 160 MHz IF frequency (D-9401-1, D-9401-2 only).  
Bandwidth: 100 MHz minimum  
Flatness: 1.0 dB/100 MHz  
Group delay ( $\pm 50$  MHz)  
Linear: 0.02 ns/MHz  
Parabolic: 0.0028 ns/MHz<sup>2</sup>  
Ripple: 1 ns peak-to-peak  
IF return loss (160  $\pm$ 50 MHz): 20 dB minimum  
Gain slope: 0.04 dB/MHz maximum (10 MHz minimum)
- 5.** Group delay equalization.
  - A.** 70 MHz IF, 1.0 ns peak-to-peak maximum  $\pm 18$  MHz.
  - B.** 140 MHz IF, 2.0 ns peak-to-peak maximum  $\pm 36$  MHz.
  - C.** 160 MHz IF, 3.0 ns peak-to-peak maximum  $\pm 50$  MHz (D-9401-1, D-9401-2 only).
- 8.** LO level alarm (9400 Series only).  
Summary alarm is generated for loss of power in any of the required local oscillators.
- 10.** Higher frequency stability reference.
  - A.**  $\pm 1 \times 10^{-8}$ , 0 to 50°C,  
5  $\times 10^{-9}$ /day typical (fixed temperature after 24 hour on time).
  - B.**  $\pm 5 \times 10^{-9}$ , 0 to 50°C,  
1  $\times 10^{-9}$ /day typical (fixed temperature after 24 hour on time).
  - C.**  $\pm 2 \times 10^{-9}$ , 0 to 50°C,  
1  $\times 10^{-9}$ /day typical (fixed temperature after 24 hour on time).
- 11.** Increased output power (upconverters).
  - A.** 5 dBm minimum power output 1 dB compression, IF/RF gain is 20 dB typical.
  - B.** 10 dBm minimum power output 1 dB compression, IF/RF gain is 30 dB typical for C- and X-band, and 26 dB typical for Ku-band.Specification of signal independent spurious increases with increase in IF/RF gain (e.g., if without option, specification is -90 dBm maximum, an increase of 10 dB in gain (Option 11A) will result in signal independent spurious of -80 dBm maximum).
- 15.** 50 ohm IF impedance.
- 16.** Higher gain option (downconverters).
  - A.** 45 dB nominal RF/IF gain.
  - C.** 55 dB nominal RF/IF gain.Specification of signal independent spurious increases with increase in RF/IF gain (e.g., if without option, specification is -90 dBm maximum, an increase of 15 dB in gain (Option 16A) will result in signal independent spurious of -75 dBm maximum).

## OPTIONS (CONT.)

- 17.** Remote control.
- A.** RS422.
  - B.** RS485 (supplied as standard).
  - C.** RS232.
  - D.** Contact closure selection of up to sixteen preprogrammed frequencies.
  - F.** IEEE-488.
  - G.** BCD contact closure.
- 18.** Multiple IF outputs (D-9401-1, D-9401-2 only).
- 18-2:** Two IF outputs.
  - 18-3:** Three IF outputs.
  - 18-4:** Four IF outputs.
  - 18-5:** Five IF outputs.
  - 18-6:** Six IF outputs.
  - 18-7:** Seven IF outputs.
  - 18-8:** Eight IF outputs.
- 19.** Input prime voltage -48 VDC.  
Connector MS3102E10SL-3P  
Pin A: -48 VDC  
Pin B: Common  
Pin C: Chassis ground
- 20.** Switchable 70 MHz and 140 MHz IF frequencies (9400 Series only).  
Two IF connectors provided at rear panel (BNC female). Selection of IF frequency is available from the front panel and over the remote bus. Unit panel height is 5.25".
- 22.** Dedicated remote control panel.  
Provides remote control and status over a dedicated RS485 bus. Option 17B (RS485 remote bus) must be ordered.
- 23.** 5 MHz reference configuration (9400 Series only).
- A.** No internal 5 MHz reference is provided. A rear panel BNC female connector is provided for external 5 MHz input (+4 ±3 dBm).
  - B.** An internal 5 MHz reference is provided. The internal 5 MHz reference is brought out of and back into the rear panel with a "U link" coaxial cable (BNC connectors). This allows, after "U link" removal, insertion of an external 5 MHz reference input (+4 ±3 dBm).
  - C.** Internal/external reference selection.  
An SPDT switch is used to select either the internal 5 MHz reference or an external 5 MHz reference. External 5 MHz reference input is through a rear panel BNC female connector (+4 ±3 dBm). Reference selection is controlled from a rear panel toggle switch.
  - D.** Automatic reference switchover.  
An internal 5 MHz reference and rear panel connector for external reference input (+4 ±3 dBm) is provided. The converter oscillators will lock to the external reference. If external reference is not present, the converter oscillators will automatically lock to the internal reference.

Notes: Missing option numbers are not applicable to this product.

For literature describing local control (front panel) and remote control (bus protocols), refer to MITEQ's Technical Note 25T010 (9400 Series) and 25T009 (9600 Series).

## 9600 SERIES (1 RU) - REAR PANEL

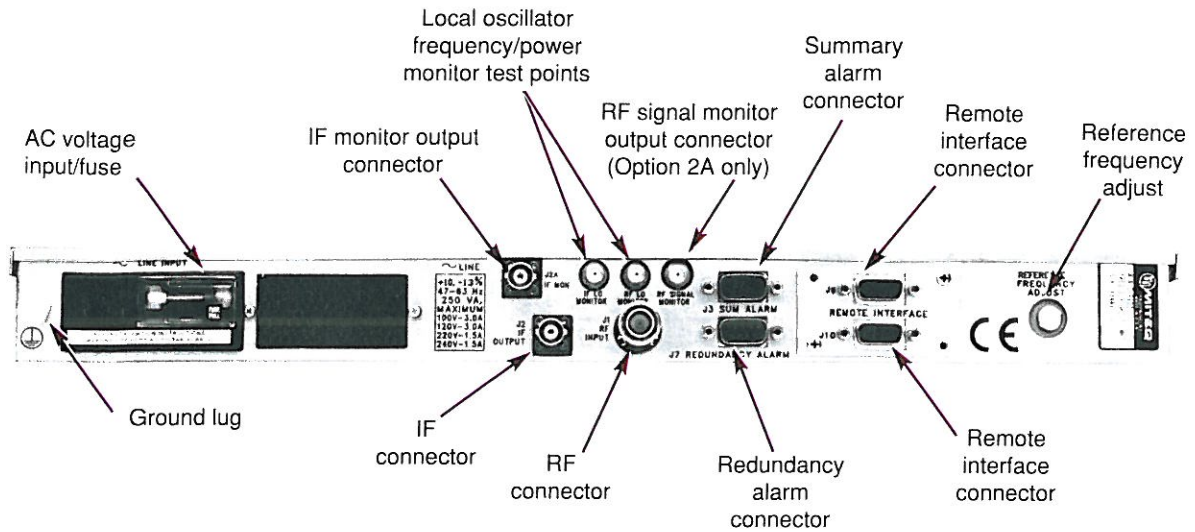

## 9400 SERIES (2 RU) - REAR PANEL

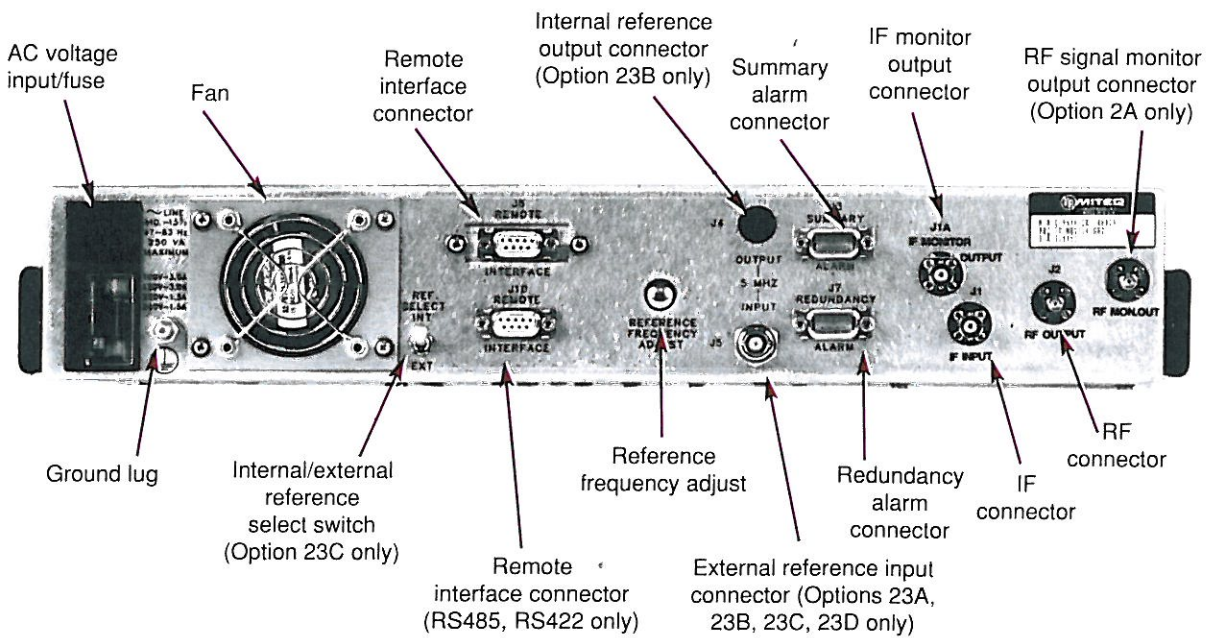

## PHASE NOISE

These phase noise curves are indicative of typical performance for a group of converters. If specific phase noise data is required for a converter, please consult the factory.

TYPICAL PHASE NOISE CHARACTERISTICS (1.0 Hz BANDWIDTH)

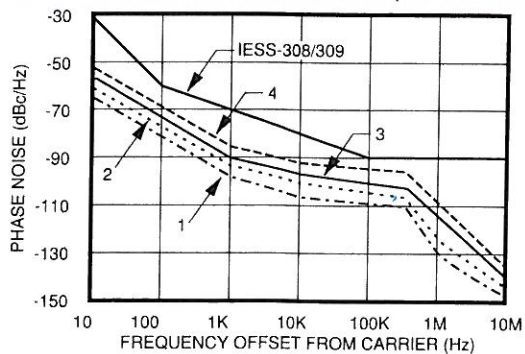

# SYNTHESIZED COMMUNICATION CONVERTERS

## PRIMARY POWER REQUIREMENTS

Voltage .....	100, 120, 220, 230/240 VAC +10%, -13% (rear panel selectable), 250 VAC maximum
Frequency .....	47-63 Hz
Power consumption .....	120 W typical

## SUMMARY ALARM

Contact closure/open for DC voltage alarm  
Contact closure/open for DC voltage and/or LO alarm

## PHYSICAL

Weight .....	20 pounds nominal
Overall dimensions .....	19" x 3.5" panel x 22" maximum (chassis depth 20") 1.75" panel height for 9600 Series
Rear panel connectors	
RF .....	N female for RF below 10.0 GHz, SMA female for RF above 10.0 GHz
IF .....	BNC female
IF signal monitor .....	BNC female
Remote interface .....	DEM-9S for RS485 and RS422, DB-25P for RS232, DB-25S for contact closure, and BCD contact closure, IEEE-488 receptacle for GPIB
Summary alarm .....	DE-9P
Redundancy alarm .....	DE-9P
LO frequency/power monitor .....	SMA female (front panel 9400 Series)

## ENVIRONMENTAL

Operating	
Ambient temperature .....	0 to 50°C
Relative humidity .....	Up to 95% at 30°C
Atmospheric pressure .....	Up to 10,000 feet
Nonoperating	
Ambient temperature .....	-50 to +70°C
Relative humidity .....	Up to 95% at 40°C
Atmospheric pressure .....	Up to 40,000 feet
Shock and vibration .....	Normal handling by commercial carriers



100 Davids Drive, Hauppauge, NY 11788  
TEL.: (631) 436-7400 • FAX: (631) 436-7431/436-7430  
www.miteq.com